



Conveyor Tracking Pad



Owner's Manual

Sonny's Enterprises, Inc.
5605 Hiatus Road
Tamarac, Florida 33321

Table of Contents

Table of Contents	2
Safety Requirements	3
Introduction.....	5
Product Features	6
Product Specifications.....	6
Parts List	7
Installation Requirements.....	7
Utilities Requirements	7
Equipment Installation	8
Warranty	11
Customer Service	12

Safety Requirements

****WARNING****

1. All employees must be thoroughly trained in safe operation and standard maintenance practices. All employees must review this entire manual monthly.
2. Do not enter the wash tunnel when the equipment is operating. Death or dismemberment may occur.
3. Do not wear loose fitting clothing or jewelry around moving equipment. Do not allow any part of your body or other objects (including ladders, hoses or tools) to come in contact with moving equipment. Entanglement may result causing death or dismemberment.
4. Do not leave a ladder or any other items such as wash down hoses or tools in the wash tunnel while equipment is running. Vehicle damage and injury, including death, can occur.
5. Always exercise caution when walking (never run) through the wash tunnel as there may be slippery conditions. Be careful so you do not bump into or trip over equipment.
6. Only those employees specifically instructed and trained by the location management are permitted to enter the wash tunnel to perform inspections or maintenance. At least two qualified maintenance people must be present when performing equipment repairs or preventive maintenance.
7. Do not perform any maintenance or work on equipment unless you first perform Lock-Out Safety Precautions. All electrically powered equipment must have manually operated disconnects capable of being locked in the "OFF" position. Equipment that has been "locked out" for any reason must be restarted only by the person who performed the "lock out" operation.
8. When working on any equipment that is higher than your shoulders, always use a fiberglass ladder that is in good condition.
9. Do not attempt to repair or adjust any pressurized liquid or pneumatic part, hose, pipe or fitting while that equipment is in operation.
10. Electrical connections and repairs must be performed by a Licensed Electrician Only.
11. Emergency "STOP" buttons must be well marked and their location and proper use reviewed with all personnel. Any activated "STOP" button must be reset only by the person who activated it. Clear the wash tunnel of any people, ladders, hoses, tools and other loose items before restarting the equipment. An audible device must sound to warn people that the equipment is starting.
12. Do not operate any piece of equipment that requires safety covers with those covers removed or improperly installed. Do not operate any piece of equipment if any component of that piece is suspected to be defective or malfunctioning.

13. Store all cleaning and washing solutions and oils in a well-ventilated area. Clean up fluid spills immediately to prevent hazardous safety conditions. Be certain to follow all safety procedures on MSDS Sheets for each chemical product used.
14. All hydraulic and electric systems in the wash tunnel equipped with a torque relief or overload should be checked and set at the minimum amount that will allow for proper functionality under normal washing conditions.
15. No unauthorized people should ever be permitted in the wash tunnel or near the equipment at any time.

* * *

!! CAUTION !!

When a piece of equipment must be in operation during inspection or maintenance, one qualified technician must stay at the power disconnect switch while another qualified technician performs the inspection or maintenance.

Introduction

This Manual contains information that is vital to the successful installation, operation and maintenance of your Sonny's vehicle washing equipment.

Please read, and understand, the full contents of this manual before installation and operation of the equipment. Keep this booklet in a location where it may be used for ongoing reference.

Should you have any questions on the operation or servicing of this equipment please contact:

**TECHNICAL SERVICES DEPT.
SONNY'S ENTERPRISES INC.
5605 Hiatus Road
TAMARAC, FLORIDA 33321**

TELEPHONE: 800-327-8723 FAX: 800-495-4049

THANK YOU FOR YOUR CONFIDENCE IN SONNY'S!



Product Features

- Reduce the potential for vehicles to jump the conveyor when pulled by the front wheel.
- Fine tunes vehicle alignment on an ultra-low friction surface to prevent damage to rims and conveyor rails.

Product Specifications

- Conveyor Tracking Pad **100ft or 130ft Roll** (Wear and Chemical Resistant PVC)
- 1/2" UHMW Retaining Bars to secure Track Pad to concrete
- 1/4" x 1 1/2" Hammer Anchors

Parts List

10013084 – Conveyor, Tracking Pad **100ft Roll** (Wear and Chemical Resistant PVC)

10013240 – Conveyor, Tracking Pad **130ft Roll** (Wear and Chemical Resistant PVC)



10013083 – Conveyor, Tracking Pad **UHMW Retainer 10ft**

10013265 – Conveyor, Tracking Pad **Anchors Box 100**



Installation Requirements

Utilities Requirements

UTILITIES INTERCONNECTION AND THE MATERIALS REQUIRED FOR INTERCONNECTION TO SONNY'S EQUIPMENT ARE THE RESPONSIBILITY OF THE CUSTOMER.

PERFORM ALL TRADES WORK TO ALL APPLICABLE LOCAL AND NATIONAL CODES.

Equipment Installation

Conveyor Tracking Pad – Mechanical Installation

Tools

1. Safety Glasses and Gloves
2. Circular Saw
3. Hammer Drill w/ ¼" Masonry Drill Bit
4. Hammer
5. Tape Measure

Work Force

Two (2) persons

Time (assuming no problems)

2.00 – 3.00 hours

Caution!

The floor surface of your tunnel may be slippery. Please use caution when performing the following installation steps.

For best results and lifespan of the Tracking Pad, the concrete surface should be smooth and free of cracks and pitting.

Installation Steps

1. Unroll the Tracking Pad. Your starting point for installing the beginning of the pad should be right after the tire pressure switch at the entrance side of the tunnel (See **Figure 2**).
2. Starting at the entrance section of the Tracking Pad, drill a ¼" hole and secure an anchor **3.75"** from the outside edge of the Tracking Pad and **1.5"** from the entrance edge through the Tracking Pad and into the Concrete. While keeping the **1.5"** spacing from the entrance edge, drill and secure **(5)** more anchors every **4.5"** (See **Figure 1**). **A total of 6 anchors should be used.**
3. Place UHMW Retainers over the Tracking Pad on the **sides** and drill ¼" holes **1"** from the outside edge through the UHMW Retainer into the concrete. For every **10'** retainer section, anchor **1"** from the end, **5"** from that anchor, then every **18"** after that. Then place **(1)** more anchor at **1"** from the other end of the extrusion. **A total of 9 anchors should be used for each 10' section. It is important that these anchors only go through the UHMW Retainer and not the Tracking Pad. This allows the Tracking Pad to expand and contract freely. Note:** If you are using partial length sections of UHMW Retainers, the anchors that are **1" from each end of the section are critical.** Use the standard anchor spacing for the remainder of the partial section.

Note: DO NOT add UHMW Retainer sections at the Entrance or Exit edges of the Tracking Pad.

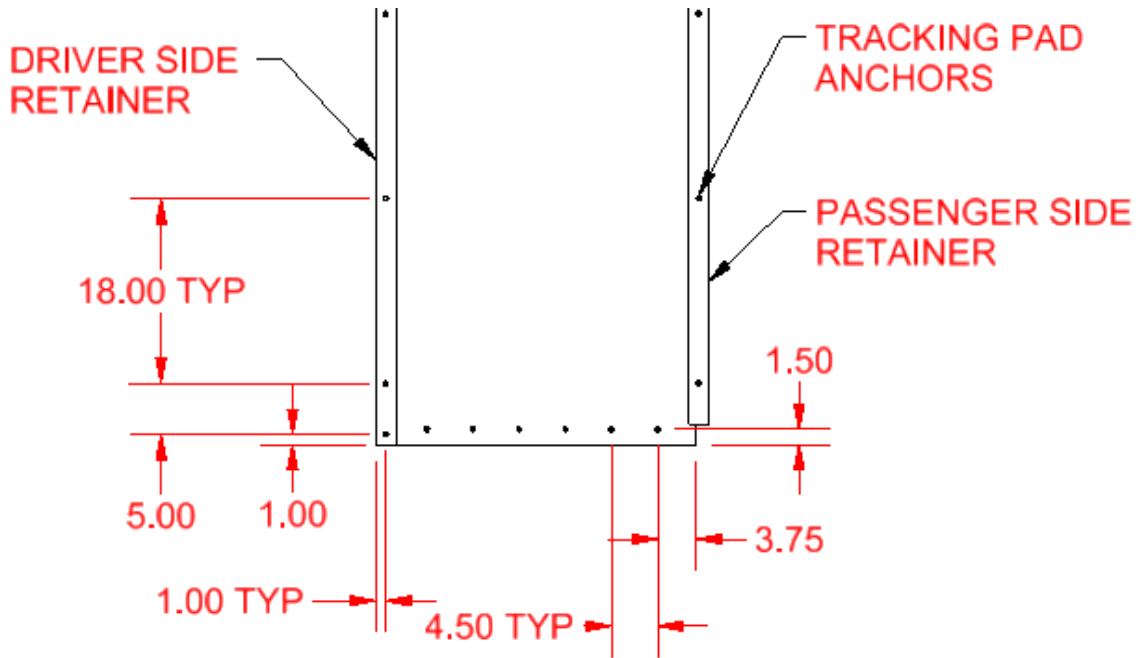

Figure 1

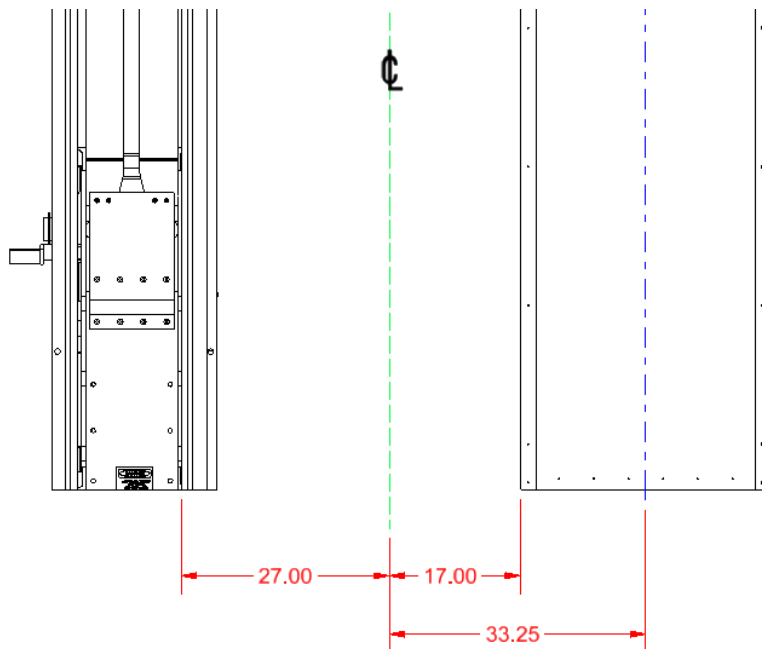

Figure 2

Tracking Pad anchors should be flush once hammered in.



Warranty

SONNY'S ENTERPRISES, INC. FACTORY LIMITED LIFETIME WARRANTY

Equipment manufactured by SONNY'S ENTERPRISES, INC. is warranted to be free from defect in material and workmanship. Welded metal framework and other non-moving, non-wearable fabricated metal components manufactured by Sonny's are warranted for the life of the equipment to the original purchaser. Fabricated metal wearable surface and moving components manufactured by Sonny's are warranted for a period of one (1) year to the original purchaser of the equipment.

All components assembled to Sonny's equipment that are manufactured by others are warranted by the appropriate manufacturer and subject to that manufacturer's limited warranty. Contact Sonny's for the specific information on other component manufacturer's warranty terms. All new PermaColor™ cloth shipped with new Sonny's equipment is warranted for a period of one (1) year, or 100,000 Car Washes, whichever occurs first. All new MicroClean™ Wash Material shipped with new Sonny's equipment is warranted for a period of one (1) year, or 60,000 Car Washes, whichever occurs first.

This warranty is not assignable or transferable. The warranty period begins the first day following installation or 30 days from the original invoice date, whichever occurs first. The Seller's liability shall be limited to repair or replacement of materials found to be defective within the warranty period. In the event of repair or replacement this limited warranty is noncumulative. The Purchaser must supply the Seller with immediate written notice when any defects are found. The Seller shall have the option of requiring the return of defective material to establish the Purchaser's claim. Neither labor nor transportation charges are included in this warranty. Transportation damage claims are to be submitted to the carrier of the damaged materials.

This warranty is based upon the Purchaser's reasonable care and maintenance of the warranted equipment. It does not apply to any equipment which has been subject to misuse, including neglect, accident or exposure to harsh chemicals, including but not limited to Hydrofluoric Acid • Ammonium Bi-fluoride • Bromic Acid • Muriatic Acid • Sulfonic Acid • Phosphoric Acid • Hydrogen Cyanide • Hydrochloric Acid • Chlorinated Solvents. Nor does it apply to any equipment which has been repaired or altered by anyone not so authorized by Sonny's. Further, the equipment must be properly installed with proper accuracy of all specified plumbing, electrical, and mechanical requirements. This warranty does not apply to normal wear and tear or routine maintenance components.

EXCEPT AS EXPRESSLY STATED HEREIN, SONNY'S SHALL NOT BE LIABLE FOR DAMAGES OF ANY KIND IN CONNECTION WITH THE PURCHASE, MAINTENANCE, OR USE OF THIS EQUIPMENT INCLUDING LOSS OF PROFITS AND ALL CLAIMS FOR CONSEQUENTIAL DAMAGES. THE LIMITED WARRANTY EXPRESSED HEREIN IS IN LIEU OF ALL OTHER WARRANTIES EXPRESSED OR IMPLIED. SONNY'S NEITHER ASSUMES NOR AUTHORIZES ANY PERSON TO ASSUME FOR IT ANY OTHER OBLIGATION OR LIABILITY IN CONNECTION HEREWITH.

Customer Service

Need more help?

For questions regarding **installation and/or operational issues and settings**, please contact Sonny's Tech Support at extension 234 or email at Sonnys-Support@SonnysDirect.com.

To order **replacement parts**, contact Customer Service at ext. 200, email us at CustomerService@SonnysDirect.com or visit us on the web at www.SonnysDirect.com.

Toll Free Main Line	800-327-8723
Local Number	954-720-4100
Customer Service	Option 3
Equipment Sales	Option 4
Technical Support	Option 5

Thank you for being a Sonny's car wash equipment owner!

From all of us here at

